

SLI0x8-201145

Suction	254mm (10")
Discharge	203mm (8")
Maximum RPM	900
Sealing System	Standard gland packing
Impeller Material	Rubber
Liner Material	Rubber
Throat Bush	Rubber
Max Motor Power	260kW
Weight-Bare	
Shaft Pump	3200kg

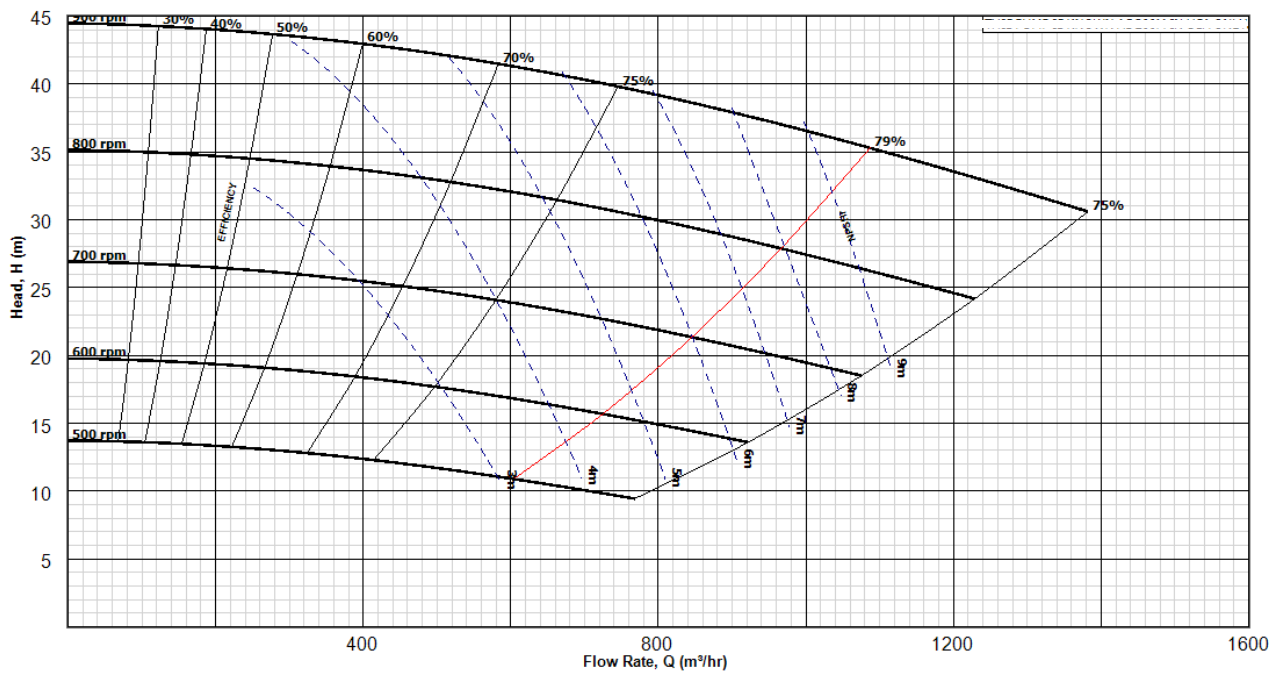

NOTE This information is for guidance / reference only. For application specific drawings and curves, please contact your nearest authorised distributor at slurrypro.com. 03.08.17

SL10x8-201145

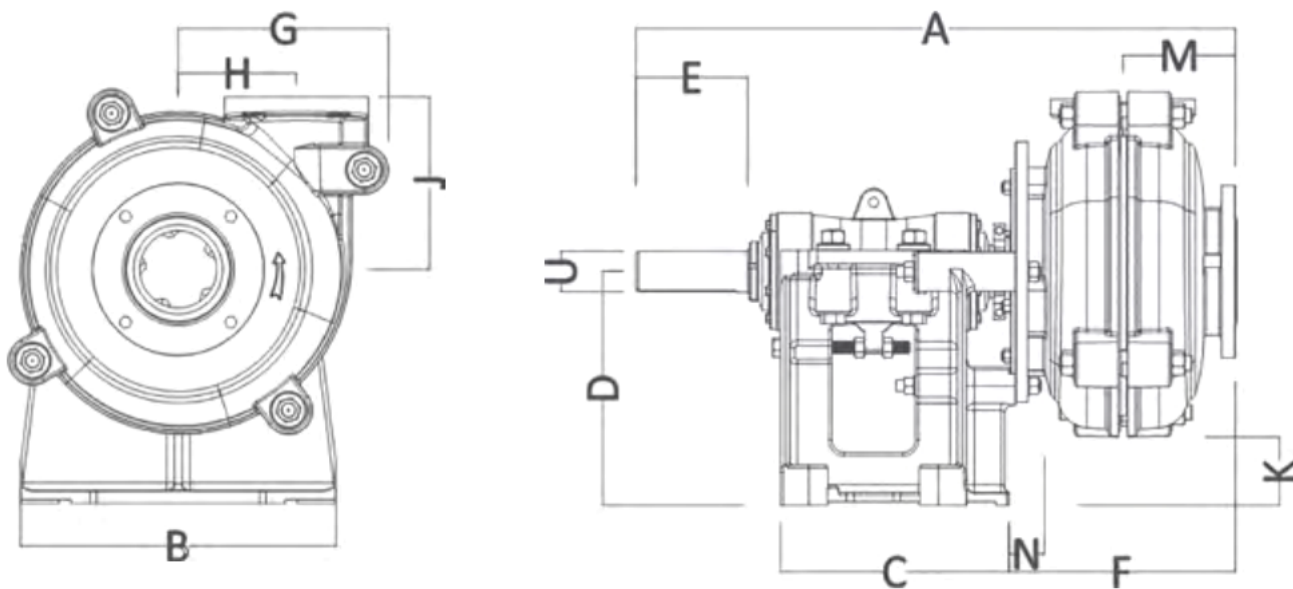

A	B	C	D	E	F	G	H
1645.92	tbc	705.1	610.11	278.89	683.01	673.1	419.1

J	K	L	M	N	U	Key Size
635	0	11.94	332.99	134.11	100	231 x 28 x 16

All values in millimetres (mm)

NOTE This information is for guidance / reference only. For application specific drawings and curves, please contact your nearest authorised distributor at slurrypro.com. 03.08.17